

G-SERIES
SMALL FRAMES



JOHN DEERE

312GR / 314G / 316GR / 317G / 318G



**MORE CHOICES,
MORE ABILITY**

316GR



PURPOSE-BU



RELIABLE

+



PRODUCTIVE

MILT FOR **ALL** YOUR PURPOSES.



YOUR INSPIRATION, OUR INNOVATION.

Before hitting the G-Series drawing board, we hit the phones and the road — connecting with skid steer and compact track loader (CTL) users like you to find out what they need. We listened, then rolled up our sleeves and applied what we learned. The result? Five compact models in vertical-lift and radial-boom configurations. With a look and feel like their larger siblings, plus amped-up specs and a wider variety of options, these reimagined do-it-alls have what it takes to fit the way you work, wherever you work.

SMALL MACHINES. BIG RESULTS

DON'T LET THE SIZE FOOL YOU.

Whether you're acquiring your first machine or adding to a fleet, there's a John Deere G-Series Skid Steer or CTL that's all-in for you.

Value-packed models

Equipped with fuel-efficient diesels, the radial-lift 312GR and vertical-lift 314G Skid Steers are easy to operate, own, and appreciate.

More power and options

If you're seeking a more powerful, better-equipped machine, step up to the radial-lift 316GR and vertical-lift 318G Skid Steers. These larger-performance models also offer more options including joystick controls, air conditioning, and ride control, to list just a few.

When smaller is smarter

Wheel options enable G-Series machines to slim down and fit through narrow openings.

Pick up the pace

Two-speed option in the 316GR and 318G provides faster transport speeds, to help boost productivity.

Beast mode

Check the 317G CTL specs. Exceptional pushing power and breakout force deliver the tractive effort and leverage to dig in where other machines just spin.

Hydraulic boost

Make the most of an even broader range of attachments with higher auxiliary flow rates on the 316GR, 318G, and 317G CTL than on previous models.

Lightweight transport

With weights from only 5,905 to 8,423 pounds and convenient front and rear tie-downs, these compacts are easy to trailer behind a standard pickup truck.

Generous FT4 power

Turbocharged 2.1-L EPA Final Tier 4 (FT4)/EU Stage IV diesels meet rigid emission standards, run smooth, and pack plenty of power and torque.

Dig, pry, push

Ample axle torque and optimized boom and bucket breakout forces help carve out clay, push through piles, and keep the bucket heaped.

Tread lightly

Equipped with optional 15.8-inch-wide track, the 317G CTL's ground pressure is just 4.5 psi, enabling work in soft underfoot conditions and side-slope stability. With standard 12.6-inch-wide track, ground pressure is only 5.5 psi.

Space commander

With widths at less than 72 inches with optional 15.8-inch track and just over 65 inches with standard 12.6-inch track, little gets in the way of the 317G CTL. Its small stature makes it easy to trailer, too.



AUXILIARY FLOW* BOOSTS ATTACHMENT PERFORMANCE

*WITH A 316GR OR 318G SKID STEER,
OR 317G CTL.



STANDOUT FEATURE



***ELEVATED.
BY DESIGN.***



BOOM LIFT

RADIAL OR VERTICAL

These reimagined loaders rise high, pick up heavy loads, and deliver remarkable boom- and bucket-breakout forces. Plus, a low center of gravity and sure-footed balance provide exceptional agility and stability on slopes. Choose between vertical or radial lift to match your application.

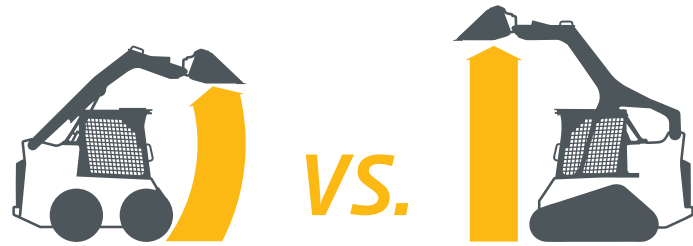

WHAT'S THE DIFFERENCE?

RADIAL LIFT

More reach at mid-range lift heights; good for digging, grading, and backfilling.

VERTICAL LIFT

More lift height and reach at the top of the lift path, for more stability.

Power lifter

Vertical-lift boom rises to 10 feet 1 inch. Combined with a rated operating capacity of 2,125 pounds, the 317G CTL precisely places pallets and carries big loads.

Boom-diggity

Radial-lift booms on the 312GR and 316GR provide powerful digging performance and generous reach at a competitive price. For even more lifting ability, opt for the 314G, 318G, or 317G CTL with vertical-lift booms that deliver outstanding lifting and truck-loading ability.

Carry more, spill less

Both radial- and vertical-lift designs keep the load close to the machine, for reliable stability. Low center of gravity, 30-degree bucket rollback, optional hydraulic self-leveling, and optional ride control (316GR, 318G, and 317G CTL only) also help keep buckets full and forks loaded. Add more capacity with up to two sets of counterweights.



TAKE A LOAD OFF

ENHANCED ABILITY — AND COMFORT, TOO.

With our G-Series, compact doesn't mean cramped. Larger entryways with doors that swing out make it easier to get in, get comfortable, and get on with it. Inside, there's more foot- and legroom. Sealing and cab pressurization have been improved over previous models to help keep the dust out and the noise down, so you can focus on work — and even enjoy the hands-free Bluetooth® radio for streaming your favorite media. Operators will also appreciate what they see from the comfortable sculpted seat. Clear sightlines to the cutting edge and bucket corners, above and below the lift arms, and the jobsite ahead and behind instill confidence when working in close quarters.



**REARVIEW
CAMERA OPTION**
ENHANCES VISIBILITY

Heads-up operation

Overhead panel conveniently places machine info on the left, control switches to the right. Easy-to-read LCD monitor provides a wealth of info and control — including vital operating conditions and advanced diagnostics.

Push-button convenience

Optional sealed-switch module provides access to keyless start and anti-theft settings, plus fingertip activation of numerous machine functions including optional ride control (316GR, 318G, and 317G CTL only) and hydraulic self-leveling.

Safety first

Standard to all John Deere machines, personal-protection features abound. An in-cab-activated boom lock and a triple-interlock system that detects the presence of the operator help keep harm's way at bay.

Your controls, your way

Low-effort foot pedals are standard on all skid steers. Electrohydraulic (EH) joysticks are standard on the 317G CTL, optional on 316GR and 318G Skid Steers.

Four-season comfort

For year-round comfort, air conditioning is available in the 316GR, 318G, and 317G CTL. On EH models, ducts and vents are optimally positioned to maximize airflow.

Enhanced visibility

Excellent all-around visibility has been further enhanced with an LED side-lighting option (316GR, 318G, and 317G CTL only). Choose the optional rearview camera, available on all models, to see the jobsite behind the machine.

Riding high

Adjustable high-back sculpted seat provides daylong comfort and support. For even more comfort, a heated air-ride seat is available on the 316GR, 318G, and 317G CTL.



LIGHTWEIGHT AGILITY.
**HEAVY-DUTY
DURABILITY**

BIG-TIME UPTIME

MORE EFFICIENT IN EVERY WAY.

Incorporating many of the same durability and reliability features found on our larger machines, the G-Series is as tough as they come. Uptime advantages such as rugged Yanmar engines, in-boom hydraulic lines and wiring, large coolers, and extended service intervals help keep downtime down. Plus, a standard automatic shutdown system prevents overheating or low fluids from ruining more than just your day. When you know how they're built, you'll see what they can do.

Heavy-duty drivetrains

Oil-bathed final-drive chains withstand daily punishment and never need adjustment. Beefed-up drive sprockets also deliver long-term durability.

Easy refills

Refueling and other fluid additions are convenient and quick. Generous tank capacity and fuel-efficient diesels enable daylong operation, letting you accomplish more between fill-ups.

Big biceps

Large cross-section boom arms and heavy-duty upper links deliver the stamina to endure tough tasks, for long-term durability.

Hydraulics in boom

Auxiliary hydraulic lines and wiring are routed through the boom, where they're protected from damage.

Chill out

Large coolers increase heat rejection for uninterrupted performance in severe, high-load conditions. Engine-mounted, belt-driven cooling fan delivers efficient, reliable performance.



8+ HOURS
OF RUN TIME BETWEEN REFILLS*

*FUEL CONSUMPTION VARIES BY
APPLICATION AND MACHINE USE.

INCREASE UTILIZATION

MULTITASKING MADE EASIER.

With over 100 models of available John Deere attachments, your G-Series Skid Steer or CTL can be hooked up with a wide variety of options. And with the universal Quik-Tatch,[™] you can go from bucket, to forks, to whatever, in just seconds. Each compact model delivers plenty of standard hydraulic power to operate augers, roller levels, trenchers, or power rakes, to list just a few.



Bucket choices abound

Choose from multipurpose, dirt, rock, and rollout buckets in varying widths and capacities. Grading-heel bucket excels at back dragging.

Grab and go

Scrap grapples feature two dual-action hydraulic-powered grapples that grab and grip. Rock grapples are ideal for tasks such as land clearing, jobsite cleanup, and brush removal.

Snow attachments

Equipped with a snow blower, snow pusher, snow/utility/V-blade or angle broom, G-Series machines make quick work of clearing whatever winter drops your way.



100+ MODELS OF JOHN DEERE ATTACHMENTS



Roadwork made easy

Perfect for concrete or asphalt flatwork, our angle brooms, vibratory rollers, cold planers, hydraulic hammers, and wide variety of buckets let you hit the road running.

Landscape add-ons

Landscape and nursery options include planetary augers, pallet forks, power rakes, dozer blades, and roller levels, to list just a few.

Busybody

With go-everywhere rubber track undercarriage, universal Quik-Tatch, and auxiliary hydraulics, the 317G CTL is fully equipped to tackle a seemingly endless variety of tasks.

Farm hands

For handling hay, cleaning pens, rebedding stalls, or numerous other agricultural chores, add silage defacers, material/manure scrapers, pallet forks, bale spears, and buckets to get it done.

WE SWEAT THE DETAILS

SO YOU DON'T HAVE TO.

Simple serviceability

Swing-out rear door enables easy, ground-level access to daily service checkpoints and cooling system components. If major component access is necessary, the ROPS can be tilted in less than five minutes.

Minimal maintenance

Redesigned Quik-Tatch system is optimized for effortless reach to grease zerks, minimizing maintenance time and expense.

JDLINK™ machine monitoring

Optional JDLINK provides machine location data and health alerts to help you decrease costly downtime.

Full-tilt access

Swing open the rear door and tilt up the hood for convenient ground-level reach to dipsticks, fuel- and fluid-filler necks, and filters. For easy drivetrain reach, the operator's station also swings up and out of the way in less than two minutes.



Easier cooler cleanout

Hinged rear door and hydraulic cooler swing open, making trash removal and core cleanout simple. Latched coolers separate easily without the need for tools.

Simplified checks

Color-coded handles and caps on conveniently positioned dipsticks and filler necks simplify checks and additions. See-through reservoirs and sight gauges let you check fuel, hydraulic oil, and windshield washer fluid levels at a glance.

Easy cleanup

If you're a neat freak or run a rental yard, you'll appreciate the convenient floor access that helps speed maintenance. Cab side windows also remove easily for cleaning.

Quick changes

Spin-on engine oil and fuel filters mounted remotely behind the rear door allow quick changes. Extended service intervals reduce downtime for scheduled maintenance, too.

Handy boom tie-down

Integrated boom tie-down enables easy access without having to crawl under the machine to connect chains for transport.





312GR / 316GR SPECIFICATIONS

Engine	312GR	316GR
Manufacturer and Model	Yanmar 4TNV86CT	Yanmar 4TNV86CT
Non-Road Emission Standard	EPA Final Tier 4/EU Stage IV	EPA Final Tier 4/EU Stage IV
Cylinders	4	4
Net Power (SAE J1349 / ISO 9249)	35.8 kW (48 hp) at 2,600 rpm	45.6 kW (61 hp) at 2,600 rpm
Gross Rated Power (ISO 14396)	37.8 kW (51 hp) at 2,600 rpm	48.5 kW (65 hp) at 2,600 rpm
Peak Torque	168 Nm (124 ft.-lb.) at 1,690 rpm	207 Nm (153 ft.-lb.) at 1,690 rpm
Displacement	2.1 L (128 cu. in.)	2.1 L (128 cu. in.)
Rated Engine Speed	2,600 rpm	2,600 rpm
Torque Rise	21% at 1,690 rpm	21% at 1,690 rpm
Aspiration	Turbocharged	Turbocharged
Air Cleaner	Dry dual element	Dry dual element
Cooling	312GR / 316GR	
Fan Type	Direct belt drive	
Powertrain	312GR	316GR
Type	Hydrostatic-manual or electrohydraulic (EH); 4 – 80 heavy-duty (HD) continuous-loop chain	
Speeds		
Single	10.8 km/h (6.7 mph)	11.1 km/h (6.9 mph)
2 Speed, High	—	16.3 km/h (10.1 mph)
Axles	Induction-hardened, one-piece forged axle shafts with maintenance-free oil-bath lubrication of inner and outer axle bearings	
Maximum Axle Torque	4664 Nm (3,440 lb.-ft.)	6459 Nm (4,764 lb.-ft.)
Tractive Effort	2565 kgf (5,655 lbf)	3552 kgf (7,831 lbf)
Final Drive	High-strength, adjustment-free chains	
Brakes	Integral, automatic, spring-applied, hydraulically released, wet-disc park brake	
Hydraulics		
Pump Flow, Standard	63 L/m (17 gpm)	63 L/m (17 gpm)
System Pressure at Couplers	22 408 kPa (3,250 psi)	23 787 kPa (3,450 psi)
Hydraulic Horsepower Flow (calculated), Standard	23 kW (31 hp)	25 kW (33 hp)
Auxiliary Hydraulics	With flat-faced couplers	Optional connect-under-pressure with flat-faced couplers
Cylinders	312GR / 316GR	
Type	John Deere heat-treated, chrome-plated polished cylinder rods, hardened steel (replaceable bushings) pivot pins	
Electrical	312GR	316GR
Voltage	12 volt	12 volt
Battery Capacity	750 CCA standard / 925 CCA with optional cold weather start package	750 CCA standard / 925 CCA with optional cold weather start package
Alternator Rating	70 amp	70 amp with no air conditioning (A/C) / 90 amp with A/C
Lights		
Standard	Halogen: 2 front and 1 rear	Halogen: 2 front and 1 rear
Deluxe	—	LED: 2 front, 2 side, and 1 rear
Operator's Station	312GR / 316GR	
ROPS (ISO 3471) / FOPS (ISO 3449) structure with quick pivot standard		
Tires/Wheels		
Standard Tire Size	10 x 16.5	
Serviceability		
Refill Capacity		
Fuel Tank	71 L (19 gal.)	
Operating Weights	312GR	316GR
Base Machine	2680 kg (5,905 lb.)	2806 kg (6,180 lb.)

While general information, pictures, and descriptions are provided, some illustrations and text may include product options and accessories NOT AVAILABLE in all regions, and in some countries products and accessories may require modifications or additions to ensure compliance with the local regulations of those countries.

312G R / 316G R SPECIFICATIONS



Machine Dimensions	312GR / 316GR
A Length Without Bucket	2.63 m (103.0 in.) (8 ft. 7 in.)
B Length With Foundry Bucket	3.24 m (127.6 in.) (10 ft. 8 in.)
C Width Without Bucket	1.60 m (62.9 in.) (5 ft. 3 in.)
D Height to Top of ROPS	1.96 m (77.2 in.) (6 ft. 5 in.)
E Height to Hinge Pin	2.92 m (115.1 in.) (9 ft. 7 in.)
F Dump Height With Foundry Bucket	2.25 m (88.6 in.) (7 ft. 5 in.)
G Dump Reach	
With Foundry Bucket	0.40 m (15.8 in.)
With Construction Bucket	0.58 m (22.8 in.)
H Wheelbase	1.05 m (41.5 in.) (3 ft. 5 in.)
I Ground Clearance	0.18 m (7.0 in.)
J Angle of Departure	22.3 deg.
K Front Turn Radius With Foundry Bucket	2.01 m (79.0 in.) (6 ft. 7 in.)
L Dump Angle (full lift height)	45 deg.
M Bucket Rollback (ground level)	30 deg.

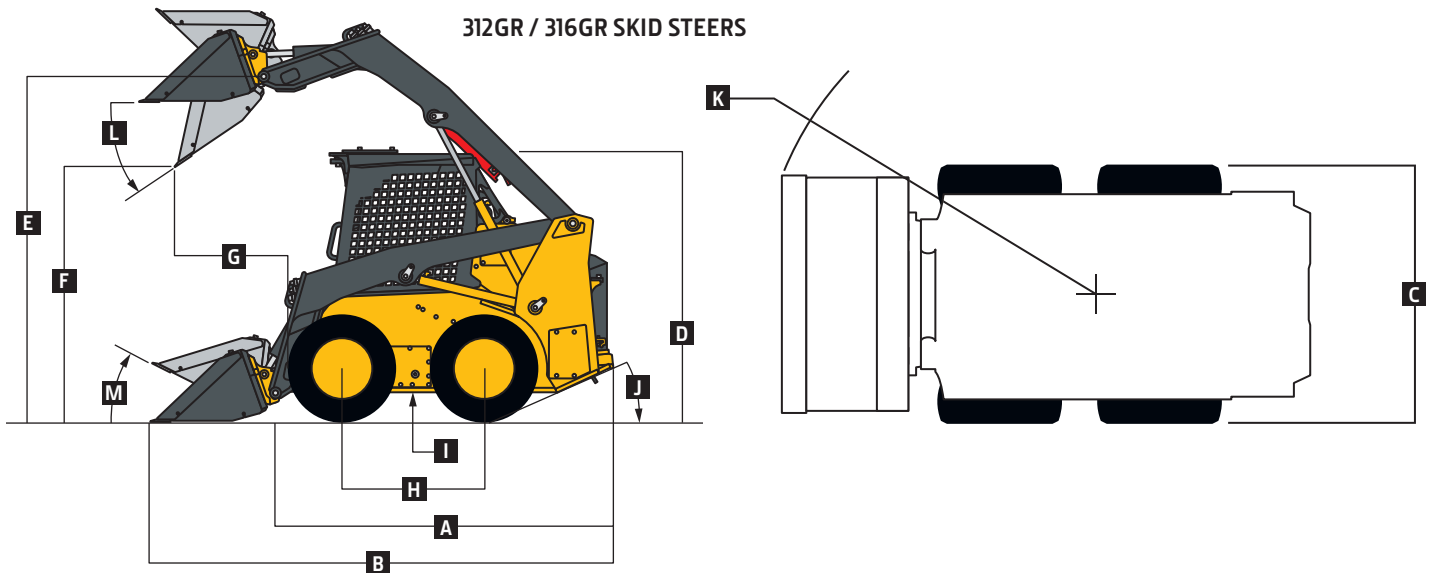

Loader Performance	312GR	316GR
Tipping Load	1407 kg (3,100 lb.)	1589 kg (3,500 lb.)
SAE Rated Operating Capacity	704 kg (1,550 lb.)	795 kg (1,750 lb.)
With Counterweight	772 kg (1,700 lb.)	863 kg (1,900 lb.)
Boom Breakout Force		
With Foundry Bucket	2043 kg (4,500 lb.)	2157 kg (4,750 lb.)
With Construction Bucket	1816 kg (4,000 lb.)	2043 kg (4,500 lb.)
Bucket Breakout Force		
With Foundry Bucket	2270 kg (5,000 lb.)	2384 kg (5,250 lb.)
With Construction Bucket	1680 kg (3,700 lb.)	1816 kg (4,000 lb.)

While general information, pictures, and descriptions are provided, some illustrations and text may include product options and accessories NOT AVAILABLE in all regions, and in some countries products and accessories may require modifications or additions to ensure compliance with the local regulations of those countries.



314G / 318G

SPECIFICATIONS

Engine	314G	318G
Manufacturer and Model	Yanmar 4TNV86CT	Yanmar 4TNV86CT
Non-Road Emission Standard	EPA Final Tier 4/EU Stage IV	EPA Final Tier 4/EU Stage IV
Cylinders	4	4
Net Power (SAE J1349 / ISO 9249)	35.8 kW (48 hp) at 2,600 rpm	45.6 kW (61 hp) at 2,600 rpm
Gross Rated Power (ISO 14396)	37.8 kW (51 hp) at 2,600 rpm	48.5 kW (65 hp) at 2,600 rpm
Peak Torque	168 Nm (124 ft.-lb.) at 1,690 rpm	207 Nm (153 ft.-lb.) at 1,690 rpm
Displacement	2.1 L (128 cu. in.)	2.1 L (128 cu. in.)
Rated Engine Speed	2,600 rpm	2,600 rpm
Torque Rise	21% at 1,690 rpm	16% at 1,690 rpm
Aspiration	Turbocharged	Turbocharged
Air Cleaner	Dry dual element	Dry dual element
Cooling	314G / 318G	
Fan Type	Direct belt drive	
Powertrain	314G	318G
Type	Hydrostatic-manual; 4 – 80 heavy-duty (HD) continuous-loop chain	Hydrostatic-manual or electrohydraulic (EH); 4 – 80 HD continuous-loop chain
Speeds		
Single	10.8 km/h (6.7 mph)	11.1 km/h (6.9 mph)
2 Speed, High	—	16.3 km/h (10.1 mph)
Axles	Induction-hardened, one-piece forged axle shafts with maintenance-free oil-bath lubrication of inner and outer axle bearings	
Maximum Axle Torque	4664 Nm (3,440 lb.-ft.)	6459 Nm (4,764 lb.-ft.)
Tractive Effort	3318 kgf (5,655 lbf)	3552 kgf (7,831 lbf)
Final Drive	High-strength, adjustment-free chains	High-strength, adjustment-free chains
Brakes	Integral, automatic, spring-applied, hydraulically released, wet-disc park brake	
Hydraulics		
Pump Flow, Standard	63 L/m (17 gpm)	63 L/m (17 gpm)
System Pressure at Couplers	22 408 kPa (3,250 psi)	23 787 kPa (3,450 psi)
Hydraulic Horsepower Flow (calculated), Standard	23 kW (31 hp)	25 kW (33 hp)
Auxiliary Hydraulics	With flat-faced couplers	Optional connect-under-pressure with flat-faced couplers
Cylinders	314G / 318G	
Type	John Deere heat-treated, chrome-plated polished cylinder rods, hardened steel (replaceable bushings) pivot pins	
Electrical	314G	318G
Voltage	12 volt	12 volt
Battery Capacity	750 CCA standard / 925 CCA with optional cold weather start package	750 CCA standard / 925 CCA with optional cold weather start package
Alternator Rating	70 amp	70 amp with no air conditioning (A/C) / 90 amp with A/C
Lights		
Standard	Halogen: 2 front and 1 rear	Halogen: 2 front and 1 rear
Deluxe	—	LED: 2 front, 2 side, and 1 rear
Operator's Station	314G / 318G	
ROPS (ISO 3471) / FOPS (ISO 3449) structure with quick pivot standard		
Tires/Wheels		
Standard Tire Size	10 x 16.5	
Serviceability		
Refill Capacity		
Fuel Tank	71 L (19 gal.)	
Operating Weight	314G	318G
Base Machine	2788 kg (6,140 lb.)	2970 kg (6,542 lb.)

While general information, pictures, and descriptions are provided, some illustrations and text may include product options and accessories NOT AVAILABLE in all regions, and in some countries products and accessories may require modifications or additions to ensure compliance with the local regulations of those countries.

314G / 318G

SPECIFICATIONS



Machine Dimensions	314G / 318G
A Length Without Bucket	2.63 m (103.0 in.) (8 ft. 7 in.)
B Length With Foundry Bucket	3.24 m (127.6 in.) (10 ft. 8 in.)
C Width Without Bucket	1.60 m (62.9 in.) (5 ft. 3 in.)
D Height to Top of ROPS	1.96 m (77.2 in.) (6 ft. 5 in.)
E Height to Hinge Pin	3.05 m (120.0 in.) (10 ft. 0 in.)
F Dump Height With Foundry Bucket	2.40 m (94.3 in.) (7 ft. 10 in.)
G Dump Reach	
With Foundry Bucket	0.86 m (34.0 in.)
With Construction Bucket	1.05 m (41.3 in.) (3 ft. 5 in.)
H Wheelbase	1.05 m (41.5 in.) (3 ft. 5 in.)
I Ground Clearance	0.18 m (7.0 in.)
J Angle of Departure	22.3 deg.
K Front Turn Radius With Foundry Bucket	2.01 m (79.0 in.) (6 ft. 7 in.)
L Dump Angle (full lift height)	42 deg.
M Bucket Rollback (ground level)	30 deg.

314G / 318G SKID STEERS

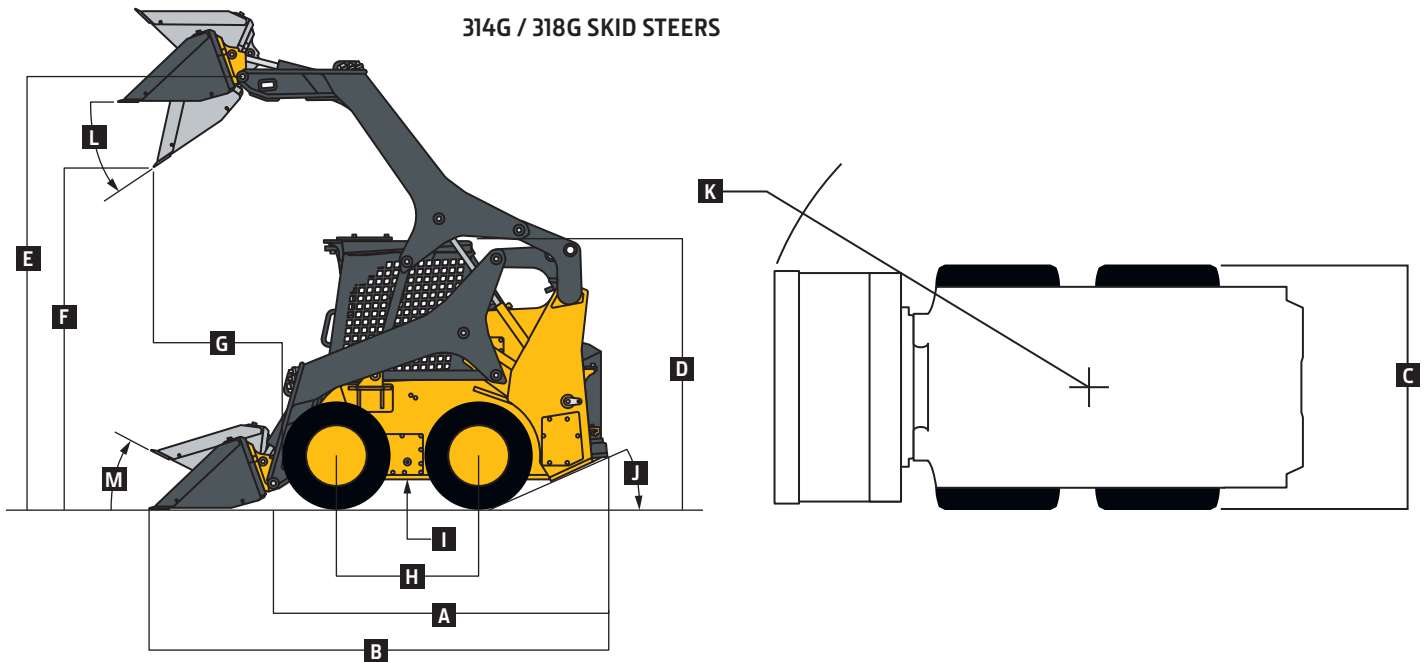

Loader Performance	314G	318G
Tipping Load	1598 kg (3,520 lb.)	1766 kg (3,890 lb.)
SAE Rated Operating Capacity	799 kg (1,760 lb.)	883 kg (1,945 lb.)
With Counterweight	863 kg (1,900 lb.)	951 kg (2,095 lb.)
Boom Breakout Force		
With Foundry Bucket	2043 kg (4,500 lb.)	2384 kg (5,250 lb.)
With Construction Bucket	1816 kg (4,000 lb.)	2270 kg (5,000 lb.)
Bucket Breakout Force		
With Foundry Bucket	2270 kg (5,000 lb.)	2724 kg (6,000 lb.)
With Construction Bucket	1589 kg (3,500 lb.)	1930 kg (4,250 lb.)

While general information, pictures, and descriptions are provided, some illustrations and text may include product options and accessories NOT AVAILABLE in all regions, and in some countries products and accessories may require modifications or additions to ensure compliance with the local regulations of those countries.



317G SPECIFICATIONS

Engine		317G
Manufacturer and Model	Yanmar 4TNV86CHT	
Non-Road Emission Standard	EPA Final Tier 4/EU Stage IV	
Cylinders	4	
Net Power (SAE J1349 / ISO 9249)	45.6 kW (61 hp) at 2,600 rpm	
Gross Rated Power (ISO 14396)	48.5 kW (65 hp) at 2,600 rpm	
Peak Torque	207 Nm (153 ft.-lb.) at 1,690 rpm	
Displacement	2.1 L (128 cu. in.)	
Rated Engine Speed	2,600 rpm	
Torque Rise	16% at 1,690 rpm	
Aspiration	Turbocharged	
Air Cleaner	Dry dual element	
Cooling		
Fan Type	Direct belt drive	
Powertrain		
Pump	Axial-piston hydrostatic	
Motors	Axial-piston hydrostatic	
Single Speed	11.3 km/h (7.0 mph)	
Gearbox	High-drive direct-drive motor	
Brakes	Integral, automatic, spring-applied, hydraulically released, wet-disc park brake	
Undercarriage		
Rubber Tracks	Smooth-ride long-life rubber with steel inserts	
Ground Pressure		
With Standard 320-mm (12.6 in.) Track	38 kPa (5.5 psi)	
With Optional 400-mm (15.8 in.) Wide Track	31 kPa (4.5 psi)	
Track Rollers (per side)	4 triple-flange smooth-ride all-steel rollers	
Track Idlers (per side)	1 double-flange and 1 single-flange smooth-ride all-steel rollers	
Bearings/Seals (rollers/idlers)	Heavy-duty journal bearings and metal face seals	
Tractive Effort	3632 kgf (8,000 lbf)	
Hydraulics		
Type	3-spool open-center valve	
Pump Flow, Standard	63 L/m (17 gpm)	
System Pressure at Couplers	23 787 kPa (3,450 psi)	
Hydraulic Horsepower (calculated)	25 kW (33 hp)	
Auxiliary Hydraulics	Standard connect-under-pressure with flat-faced couplers	
Cylinders		
Type	John Deere heat-treated, chrome-plated, polished cylinder rods, hardened steel (replaceable bushings) pivot pins	
Electrical		
Voltage	12 volt	
Capacity		
Battery	750 CCA standard / 925 CCA with optional cold weather start package	
Reserve	180 min.	
Alternator Rating	70 amp with no air conditioning (A/C) / 90 amp with A/C	
Lights		
Standard	Halogen: 2 front and 1 rear	
Deluxe (optional)	LED: 2 front, 2 side, and 1 rear	

While general information, pictures, and descriptions are provided, some illustrations and text may include product options and accessories NOT AVAILABLE in all regions, and in some countries products and accessories may require modifications or additions to ensure compliance with the local regulations of those countries.

317G

SPECIFICATIONS



Operator's Station 317G

ROPS (ISO 3471) / FOPS (ISO 3449) structure with quick pivot standard; keyless-start option with sealed-switch module

Serviceability

Refill Capacities

Fuel Tank	71 L (19 gal.)
Cooling System	12 L (12.7 qt.)

Operating Weights

With Standard 320-mm (12.6 in.) Track	3824 kg (8,423 lb.)
With Optional 400-mm (15.8 in.) Wide Track	3942 kg (8,683 lb.)

Machine Dimensions

A Length Without Bucket	2.63 m (103.0 in.) (8 ft. 7 in.)
B Length	
With Foundry Bucket	3.24 m (127.6 in.) (10 ft. 8 in.)
With Construction Bucket	3.49 m (137.4 in.) (11 ft. 5 in.)
C Width Without Bucket	
With Standard 320-mm (12.6 in.) Track	1.65 m (65.1 in.) (5 ft. 5 in.)
With Optional 400-mm (15.8 in.) Track	1.82 m (71.5 in.) (5 ft. 11 in.)
D Height to Top of ROPS	1.99 m (78.5 in.) (6 ft. 6 in.)
E Height to Hinge Pin	3.07 m (121.0 in.) (10 ft. 1 in.)
F Dump Height	
With Foundry Bucket	2.43 m (95.6 in.) (8 ft. 0 in.)
With Construction Bucket	2.26 m (89.0 in.) (7 ft. 5 in.)
G Dump Reach	
With Foundry Bucket	0.79 m (31.0 in.)
With Construction Bucket With Edge	0.98 m (38.6 in.) (3 ft. 3 in.)
H Ground Clearance	0.21 m (8.3 in.)
I Angle of Departure	32.3 deg.
J Front Turn Radius With Foundry Bucket	1.97 m (77.7 in.) (6 ft. 6 in.)
K Dump Angle (full lift height)	42 deg.
L Bucket Rollback (ground level)	30 deg.

Loader Performance

Tipping Load	2756 kg (6,070 lb.)
SAE Rated Operating Capacity	
At 35% Tipping Load	965 kg (2,125 lb.)
At 50% Tipping Load	1378 kg (3,035 lb.)
With Counterweight	1022 kg (2,250 lb.)
Boom Breakout Force	
With Foundry Bucket	2384 kg (5,250 lb.)
With Construction Bucket	2270 kg (5,000 lb.)
Bucket Breakout Force	
With Foundry Bucket	2724 kg (6,000 lb.)
With Construction Bucket	1930 kg (4,250 lb.)

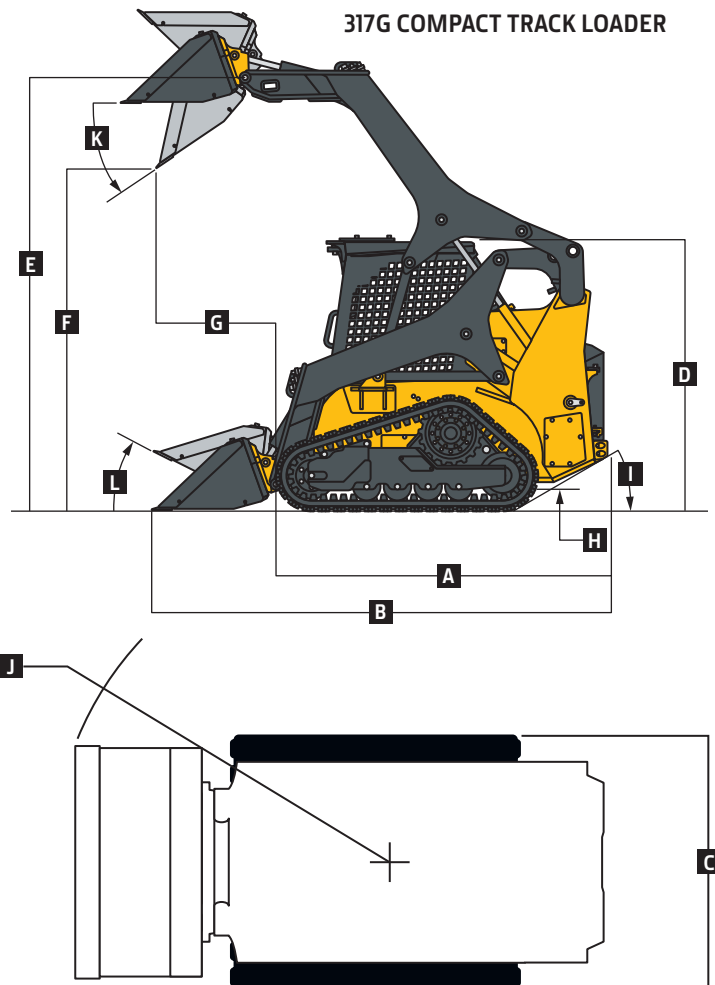

While general information, pictures, and descriptions are provided, some illustrations and text may include product options and accessories NOT AVAILABLE in all regions, and in some countries products and accessories may require modifications or additions to ensure compliance with the local regulations of those countries.

Additional equipment

Key: ● Standard ▲ Optional or special See your John Deere dealer for further information.

312GR SSL	314G SSL	316GR SSL	318G SSL	317G CTL	Engine
●	●	●	●	●	Meets EPA Final Tier 4/EU Stage IV emissions
●	●				Yanmar 4TNV86CT
		●	●	●	Yanmar 4TNV86CHT
●	●	●	●	●	Auto-idle
●	●	●	●	●	Automatic preheat
●	●	●	●	●	Electronic injection system
▲	▲	▲	▲	▲	Engine air precleaner kit
●	●	●	●	●	Fuel tank, 71 L (19 gal.)
●	●	●	●	●	John Deere COOL-GARD™ II Extended-Life Engine Coolant
●	●	●	●	●	John Deere Plus-50™ II 0W40 initial engine oil fill*
●	●				4-cylinder 37.8 kW (51 gross hp)/ 35.8 kW (48 net hp), 2.1-L (128 cu. in.) displacement
		●	●	●	4-cylinder 48.5 kW (65 gross hp)/ 45.6 kW (61 net hp), 2.1-L (128 cu. in.) displacement
●	●	●	●	●	5-micron primary fuel filter and water separator
▲	▲	▲	▲	▲	Cold-weather starting package with 925-CCA battery
Cooling System					
●	●	●	●	●	Coolant overflow bottle recovery tank
●	●	●	●	●	Direct belt-drive cooling fan system
●	●	●	●	●	No-tools-required swing-out oil cooler
Powertrain					
●	●	●	●		High-strength adjustment-free final-drive chains
				●	High-drive direct-drive motor
●	●	●	●	●	Automatic spring-applied hydraulically released wet-disc park brake
●	●	●	●	●	Transmission, single speed
		▲	▲		Transmission, 2 speed

312GR SSL	314G SSL	316GR SSL	318G SSL	317G CTL	Hydraulic System
●	●	●	●	●	John Deere heat-treated, chrome-plated cylinder rods with replaceable bushings
●	●				Flat-faced couplers
		▲	▲	●	Connect-under-pressure auxiliary couplers
●	●	●	●	●	Quick-check hydraulic fluid-level sight glass
●	●	●	●	●	1,000-hour, 5-micron hydraulic filter
●	●	●	●	●	Axial-piston hydrostatic pump
Electrical					
●	●	●	●	●	Automatic engine/hydraulic shutdown protection system
●	●	●	●	●	Auxiliary hydraulics operator-presence system
●	●	●	●	●	Courtesy lighting
●	●	●	●	●	Deluxe instrumentation EMU with: Operator-selectable monitoring – Hour meter, engine rpm, battery voltage, diagnostics, EMU configuration, engine coolant temperature, hydraulic oil temperature / LED warning indicators – Glow plug, seat switch, seat belt, door open, auxiliary hydraulics, park brake engaged, 2-speed engaged, stop, low engine oil pressure, engine coolant over-temperature, battery not charging, air filter restriction, hydraulic filter restriction
		▲	▲	▲	Deluxe LED lighting package with additional side lights (2), front lights (2), and rear light (1)
●	●	●	●	●	Front and rear halogen work lights
●	●	●	●	●	Triple-interlock operator-presence control system
●	●	●	●	●	Backup alarm
●	●	●	●	●	Battery, 750 CCA
●	●	●	●	●	Horn

*500-hour engine oil-change intervals when John Deere Plus-50 II oil and John Deere oil filter are used.

While general information, pictures, and descriptions are provided, some illustrations and text may include product options and accessories NOT AVAILABLE in all regions, and in some countries products and accessories may require modifications or additions to ensure compliance with the local regulations of those countries.

Net engine power is with standard equipment including air cleaner, exhaust system, alternator, and cooling fan, at standard conditions per SAE J1349 and DIN 6270B, using No. 2-D fuel at 35 API gravity. Gross power is without cooling fan. Specifications and design subject to change without notice. Wherever applicable, specifications are in accordance with SAE standards. Except where otherwise noted, these specifications are based on units with standard equipment, full fuel tanks, and 79-kg (175-lb.) operator.

Additional equipment *(continued)*

Key: ● Standard ▲ Optional or special See your John Deere dealer for further information.

312GR SSL	314G SSL	316GR SSL	318G SSL	317G CTL	Operator's Station
●	●	●	●	●	Deluxe cab headliner
▲	▲	▲	▲	▲	Keyless-start sealed-switch module with integrated anti-theft system
●	●	●	●	●	Pull-down adjustable lap bar
●	●	●	●	●	Quick-pivot ROPS
●	●	●	●	●	Rear window
●	●	●	●	●	Top window
●	●	●	●	●	Removable top window
▲	▲	▲	▲	▲	Vinyl cab enclosure
▲	▲	▲	▲	▲	Glass cab enclosure
▲	▲	▲	▲	▲	Sliding/locking/removable glass side windows
●	●	●	●	●	ROPS/FOPS operator structure
●	●	●	●	●	Seat belt, 51-mm (2-in.), retractable
▲	▲	▲	▲	▲	Seat belt, 76-mm (3-in.), retractable
▲	▲	▲	▲	▲	Shoulder belt
●	●	●	●	●	Water-shedding deluxe vinyl seat
▲	▲	▲	▲	▲	Deluxe vinyl suspension seat
		▲	▲	▲	Air-ride cloth, heated seat
▲	▲	▲	▲	▲	Air-ride vinyl seat
●	●	●	●	●	12-volt power port / Dome light / Cargo storage / Beverage holder
		▲	▲	▲	Air conditioning with heater/defroster
▲	▲				Heater with defroster
▲	▲	▲	▲	▲	AM/FM radio with Bluetooth® for audio streaming
		▲	▲	●	Electrohydraulic (EH) ISO-pattern joystick controls
		▲	▲	▲	EH joystick performance package: Switchable ISO-H pattern / Creeper mode / Boom/bucket speed settings / Adjustable propel settings / Attachment controls
●	●	●	●		Manual foot and hand controls
▲	▲	▲	▲	▲	Floor mat with left footrest
●	●	●	●	●	Rearview mirror
▲	▲	▲	▲	▲	Severe-duty cab door and wiper system

312GR SSL	314G SSL	316GR SSL	318G SSL	317G CTL	Operator's Station <i>(continued)</i>
▲	▲	▲	▲	▲	Boom-mounted side mirrors
▲	▲	▲	▲	▲	Rearview camera
Loader					
●	●	●	●	●	In-cab boom lockout to secure loader before exiting seat
●	●	●	●	●	John Deere Quik-Tatch™
▲	▲	▲	▲	▲	Power Quik-Tatch
●		●			John Deere radial-lift boom
	●		●	●	John Deere vertical-lift boom
▲	▲	▲	▲	▲	Hydraulic self-leveling on/off
		▲	▲	▲	Hydraulic self-leveling on/off and ride control
Other					
●	●	●	●	●	Convenient front (1) and rear (2) tie-downs
●	●	●	●	●	Environmental drains for all fluid reservoirs
▲	▲	▲	▲		10 x 16.5 10 PR Galaxy "Beefy Baby III" heavy-duty (HD) tires for 1.52-m (60 in.) machine width
▲	▲	▲	▲		Tire options: SKS Xtra Wall, Galaxy Beefy Baby III, Galaxy Hulk, and Brawler Solid-Flex
				●	320-mm (12.6 in.) tracks, 1.73-m (68 in.) wide machine stance
				▲	320-mm (12.6 in.) tracks, 1.65-m (65 in.) narrow machine stance
				▲	400-mm (15.8 in.) tracks, 1.80-m (71 in.) wide machine stance
▲	▲	▲	▲	▲	Chrome exhaust stack
▲	▲	▲	▲	▲	Rear counterweights (2), 45.36 kg (100 lb.)
▲	▲	▲	▲	▲	Single-point lift kit
▲	▲	▲	▲	▲	SMV sign kit
▲	▲	▲	▲	▲	Spare tire and wheel
▲	▲	▲	▲	▲	JDLink™ wireless communication system (available in specific countries; see your dealer for details)

While general information, pictures, and descriptions are provided, some illustrations and text may include product options and accessories NOT AVAILABLE in all regions, and in some countries products and accessories may require modifications or additions to ensure compliance with the local regulations of those countries.

Net engine power is with standard equipment including air cleaner, exhaust system, alternator, and cooling fan, at standard conditions per SAE J1349 and DIN 6270B, using No. 2-D fuel at 35 API gravity. Gross power is without cooling fan. Specifications and design subject to change without notice. Wherever applicable, specifications are in accordance with SAE standards. Except where otherwise noted, these specifications are based on units with standard equipment, full fuel tanks, and 79-kg (175-lb.) operator.



GOING THE EXTRA MILE
FOR YOU.

THERE ARE NO SMALL JOBS. Every day you go the extra mile to reflect your high standards — and you need equipment that delivers. That's why every John Deere machine is designed and built to **exceed** all your efficiency, uptime, and profitability needs — so you can **RUN YOUR WORLD.**



JOHN DEERE

JohnDeere.com



DKAGSSCE Litho in U.S.A. (20-05)